

ORDERING CODE

	F3	BHQ	4	67	D	1	A	00	
F3 - special seals for fire-resistant fluids. Omit if not required								SPECIAL CHARACTERISTICS Omit if not required 02: BSP 03: UNF 04: NPT	
PUMP TYPE BHP = 10 vane pump, industrial and mobile use, BSP, NPT & SAE threads. Only BHP1 and BHP2 BHS = 12 vane pump, industrial use, metric threads. Very quiet BHQ = 10 vane pump and bronze plates, metric threads. Mobile use								PORTING COMBINATION A: Outlet in line with inlet. B: 90° Clockwise from inlet. C: 180° from inlet. D: 90° counterclockwise from inlet. Viewed from shaft end of pump	
PUMP MODEL 1 and 2 BHP types; 4, 6 and 7 BHS and BHQ types.								SHAFT TYPE See shaft options on pump dimension pages.	
FLOW BHP, BHS and BHQ Litres per minute @1000 rpm and 7 Bar								ROTATION D = Clockwise rotation. Y = Counterclockwise Viewed from shaft end of pump	

PORTING COMBINATION

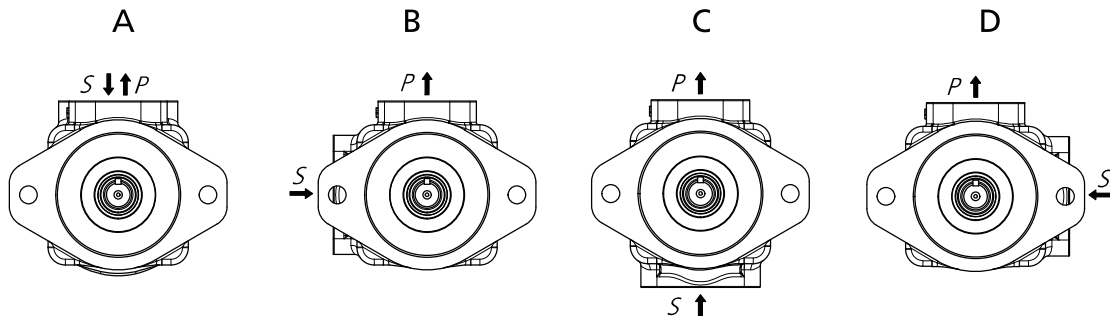

CHARACTERISTICS

TYPE	FLOW			SPEED(rpm)		PRESSURE (bar)		NOMINAL POWER	CONNECTION		WEIGHT
	TDZ	L @ 1000RPM	GAL. @ 1200RPM	REDUC-TION (1)	MIN	MAX	CONT	INTERMIT	(2)	INLET	OUTLET
BHP1	2	0,6	0,18	600	2500	150	175	0,5	(3)	(3)	1
	3	0,9						0,7			
	4,5	1,2	0,36					1			
	5,5	1,7						1,4			
	6,5	2						1,6			
BHP2	7	2,2	0,7	600	2500	150	175	1,8	(3)	(3)	3,6
	8	2,5						2			
	10	3,2	1,1					2,5			
	12	3,8						3			
	15	4,7						3,7			
BHQ4 BHS4	26	8	4,5	600	2500 1800 (BHS)	175	210	6,9	Ø38	Ø26	14,5
	40	12	5,7					10,4			
	45	14	5,8					11,6			
	55	17						13,8			
	60	19	1500		14,6						
	67	21			16,8						
	80	24			20,3						
	88*	27*			6,5			22,4			
BHQ6 BHS6	66	21	8,6	600	2400 1800 (BHS)	175	210	16,8	Ø60	Ø32	26,3
	81	25	9					20,3			
	97	30	10					24,3			
	112	35	11,4		27,4						
	121	38			29,3						
	142	45	13,1		1500			125			
BHQ7 BHS7	138	42	15	600	2200 1800 (BHS)	155	175	32,3	Ø75	Ø38	38,3
	148	47	15,7					36,3			
	162	50	14,3					37,9			
	180	57	17,9					43,2			
	193	60	18,6					46,1			
	214	67	22					51,2			
	240	75	26					57,4			

*27 gallons (88 lts.) cartridge not mounted in BHQ4 vane pump model.

(1) Delivery flow reduction in Ltrs./min. at 100 Bar. 22 cST of oil viscosity at operating temperature. To calculate the approximate delivery flow at a given pressure and speed, use the following formula with flow reduction and theoretical flow values shown in the chart. Flow reduction values are independent of shaft speed.

$$\text{Approx. output flow (Ltrs./min.)} = \text{Theoretical flow} \times \frac{\text{R.P.M}}{1000} - \text{Reduction} \times \frac{\text{Pressure (Bar)}}{1000}$$

(2) Nominal Power in H.P. at 100 Bar and 1000 RPM (to convert into Kw multiply by 0.735). To obtain the real input power at different pressure and revolutions, use the formula as follows:

$$\text{Real input power} = \text{Input power} \times \frac{\text{R.P.M}}{1000} \times \frac{\text{Pressure (Bar)}}{1000}$$

(3) See options on dimension pages.

BHP-2 DIMENSIONS

DATA SHEET

	FLOW					SPEED(rpm)		PRESSURE (bar)		CONNECTION		WEIGHT
	Lts/min.at 1000 rpm	7	8	10	12	15	Mín.	Máx.*	Contin.*	Intermit. *	Inlet	Outlet
Gal/min.at 1200 rpm	2,2	2,5	3,2	3,8	4,7	600	2500	175	210	Ø38	Ø26	1

* For further details see general chart
 DIMENSIONS IN MILLIMETERS. 1" = 25,4 mm

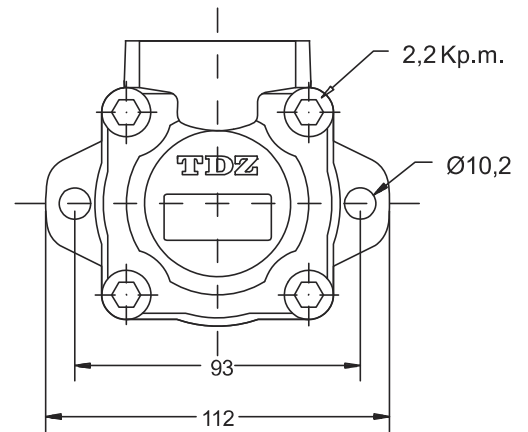
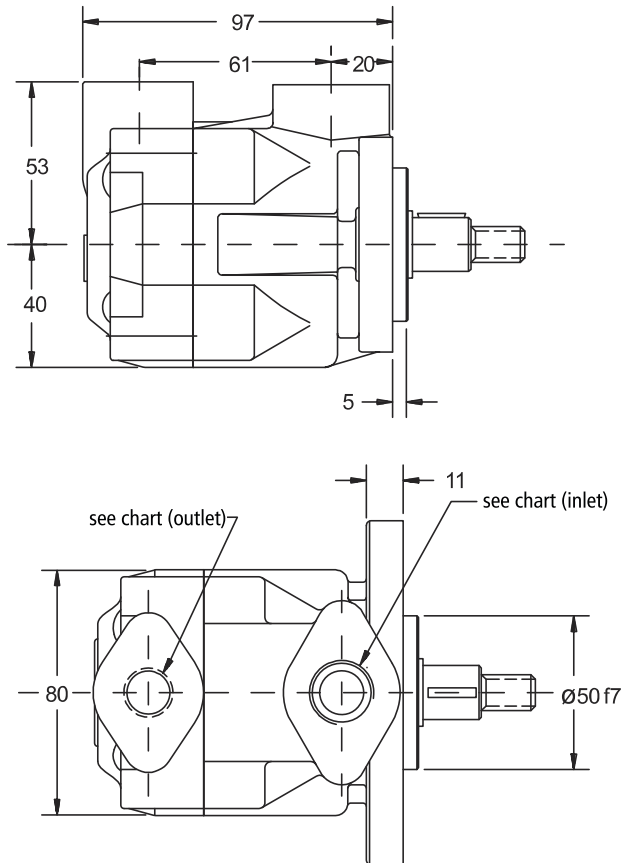

THREAD OPTIONS		
NUM.	INLET	OUTLET
02	¾" BSP	½" BSP

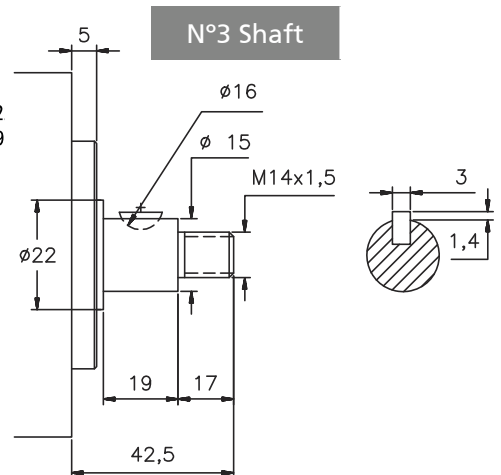
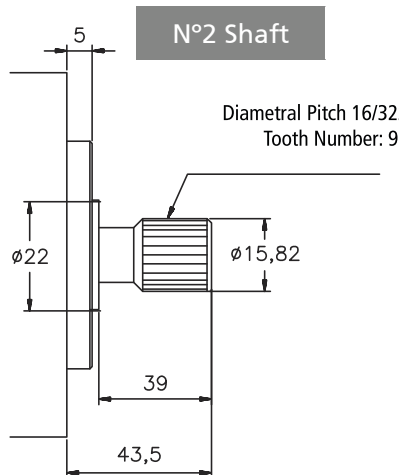
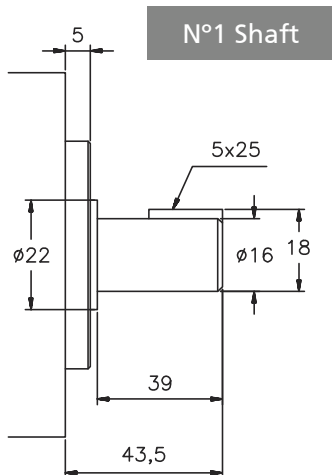

BHP-2

FLOW AND INPUT POWER DIAGRAMS

