

ORDERING CODE

DATA SHEET

	F3	VS	43	21	8	D	86	A	A
F3 - Special seals for fire-resistant fluids. Omit if not required									
VC = 12 Vane pump Medium pressure application									
VS = 12 Vane pump Except the cover end cartridge of the VS*3 pump, industrial uses (very quiet), UNC threads.									
VQ = 10 Vanes & bronze plates Mobile use, UNC threads									
PUMP MODEL 2010,2020,43,63,64,73,74, 76									
PUMP FLOW AT SHAFT SIDE US Gallons per minute @1200 rpm and 7 Bar (See flow chart)									
PUMP FLOW AT COVER SIDE US Gallons per minute @1200 rpm and 7 Bar (See flow chart)									
REAR FLANGE POSITION A: 45° Clockwise B: 135° Clockwise C: 135° Counterclockwise D: 45° Counterclockwise Viewed from shaft end of pump									
PORTING COMBINATION A: Outlet in line with inlet. B: 90° Clockwise from inlet. C: 180° From inlet. D: 90° Counterclockwise from inlet. Viewed from shaft end of pump									
SHAFT TYPE 1 - Parallel keyed 11 - Splined 86 - Heavy duty parallel keyed									
ROTATION D = Clockwise rotation. Y = Counterclockwise Viewed from shaft end of pump									

PORTING COMBINATION

2010 / 2020 / 43 / 63 / 64 / 73 / 74

SIZE 76 ONLY

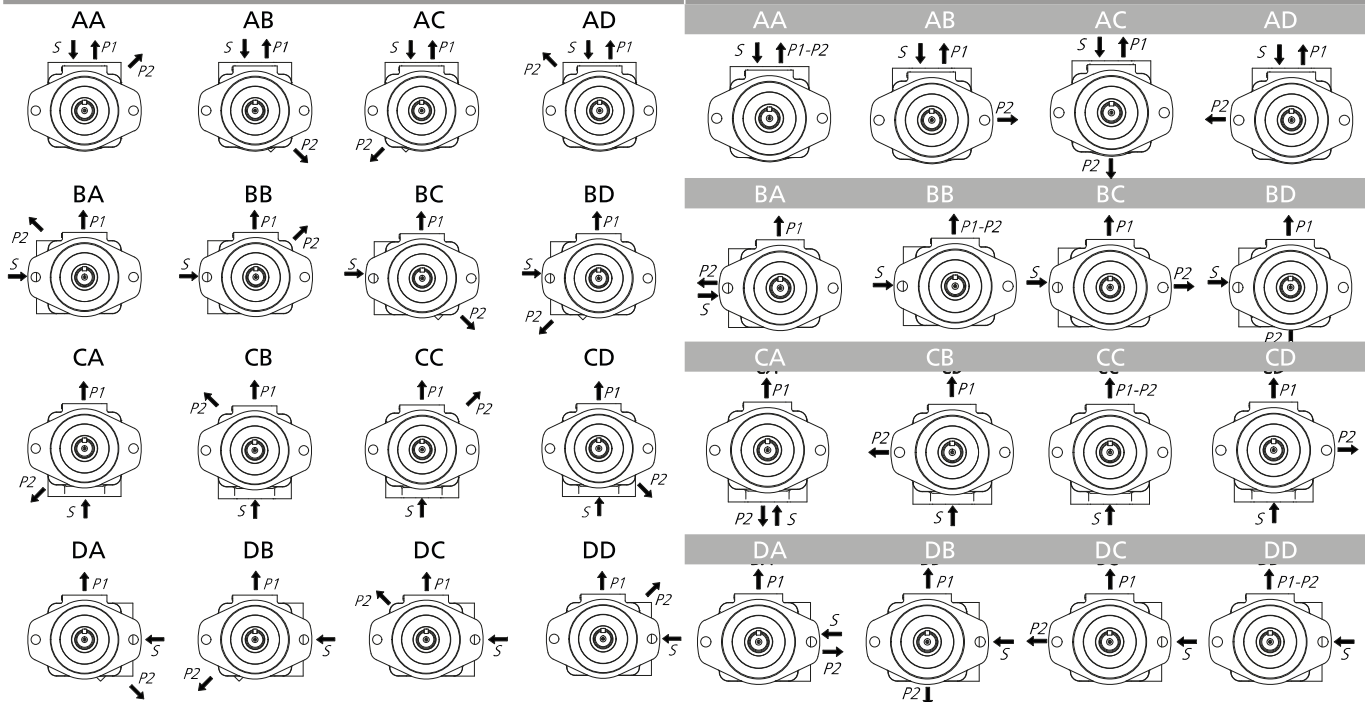

CHARACTERISTICS

TYPE	SHAFT END							COVER END							WEIGHT KG												
	FLOW			SPEED (rpm)	PRESSURE (bar)		NOMI- NAL POWER	FLOW			SPEED (rpm)	PRESSURE (bar)		NOMI- NAL POWER													
	L @ 1000RPM	GAL. @ 1200RPM	Reducc. (1)		MAX	CONT		INTERMIT	(2)	L @ 1000RPM		GAL. @ 1200RPM	Reducc. (1)			MAX	CONT	INTERMIT	(2)								
MODEL																											
VC2010	16	5	2	3400	155	180	3,2	3	1	0,8	3000	155	180	0,7	13,6												
	20	6	2,84													3,9	7	2	0,9								
	23	7	4	4,4												10	3	1,2	2,1								
	27	8	4,2	5,1												13	4	1,6	2,7								
	30	9	4,5	5,6												16	5	1,7	3,2								
	34	10	4,8	6,1												20	6	1,8	3,7								
	36	11		6,5												23	7	1,9	4,2								
	39	12	5,4	7,5												23	7	1,9	4,2								
VC2020	16	5	2	3400	155	180	3,2	16	5	2	3400	155	180	3,2	15,9												
	20	6	2,84													3,9	20	6	2,8	3,9							
	23	7	4	4,4												23	7	4	4,4								
	27	8	4,2	5,1												27	8	4,2	5,1								
	30	9	4,5	5,6												30	9	4,5	5,6								
	34	10	4,8	6,1												34	10	4,8	6,1								
	36	11		6,5												36	11	4,8	6,5								
	39	12	5,4	7,5												39	12	5,4	7,5								
VQ43 VS43	32	10	4,5	2500	175	210	6,9	8	2	0,9	2500	175	210	1,9	21												
	40	12	5,7													10,4	18	5	2,1	4							
	45	14		11,6												27	8	2,8	6,6								
	55	17		13,8												29	9	3,5	6,9								
	60	19	5,8	15,2												36	11		7,3								
	67	21	6	16,8												39	12	4,3	7,4								
	80	25	6,2	20,3												46	14		7,6								
	VQ63 VS63	66	21	8,6												2500	175	210	16,8	8	2	0,9	2500	175	210	1,9	31
81		25	9	20,3	18	5	2,1	4																			
97		30	10	24,3	27	8	2,8	6,6																			
112		35	11,4	27,3	29	9	3,5	6,9																			
121		38		29,3	36	11		7,3																			
142		45	13,1	33,3	39	12	4,3	7,4																			
VQ64 VS64		66	21	8,6	2500	175	210	16,8	32	10	4,5	2500	175	210	6,9	33											
		81	25	9																							
	97	30	10	24,3	45												14		11,6								
	112	35	11,4	27,3	55												17	5,8	13,8								
	121	38		29,3	60												19		15,2								
	142	45	13,1	33,3	67												21	6	16,8								
	VQ73 VS73	66	21	8,6	2500												175	210	16,8	80	25	6,2	2500	175	210	20,3	46
		81	25	9																							
97		30	10	24,3	27	8	2,8	6,6																			
112		35	11,4	27,3	29	9	3,5	6,9																			
121		38		29,3	36	11		7,3																			
142		45	13,1	33,3	39	12	4,3	7,4																			
VQ74 VS74		138	42	15	2200	155	175	32,3	32	10	4,5	2500	175	210	6,9	45											
		148	45	15,7																							
	162	50	14,3	37,9	45												14		11,6								
	180	57	17,9	43,2	55												17	5,8	13,8								
	193	60	18,6	46,1	60												19		15,2								
	214	67	22	51,2	67												21	6	16,8								
	240	75	26	57,4	80												25	6,2	20,3								
	VQ76 VS76	138	42	15	2200												155	175	32,3	66	21	8,6	2500	175	210	16,8	55
148		45	15,7	36,3		81	25	9	20,3																		
162		50	14,3	37,9	97	30	10	24,3																			
180		57	17,9	43,2	112	35	11,4	27,4																			
193		60	18,6	46,1	121	38		29,3																			
214		67	22	51,2	142	45	13,1	33,3																			
240		75	26	57,4																							

(1) **Delivery flow reduction** in Ltrs./min. at 100 Bar. 22 cST of oil viscosity at operating temperature. To calculate the approximate delivery flow at a given pressure and speed, use the following formula with flow reduction and theoretical flow values shown in the chart. Flow reduction values are independent of shaft speed.

$$\text{Approx. output flow (Ltrs./min.)} = \text{Theoretical flow} \times \frac{\text{R.P.M}}{1000} - \text{Reduction} \times \frac{\text{Pressure (Bar)}}{1000}$$

(2) **Nominal Power** in H.P. at 100 Bar and 1000 RPM (to convert into Kw multiply by 0.735). To obtain the real input power at different pressure and revolutions, use the formula as follows:

$$\text{Real input power} = \text{Input power} \times \frac{\text{R.P.M}}{1000} \times \frac{\text{Pressure (Bar)}}{1000}$$

(3) See options on dimension pages.

VC2010 DIMENSIONS

*mm (in)

DATA SHEET

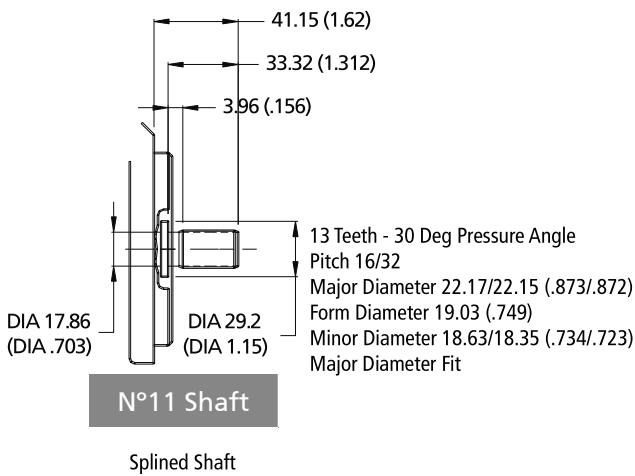
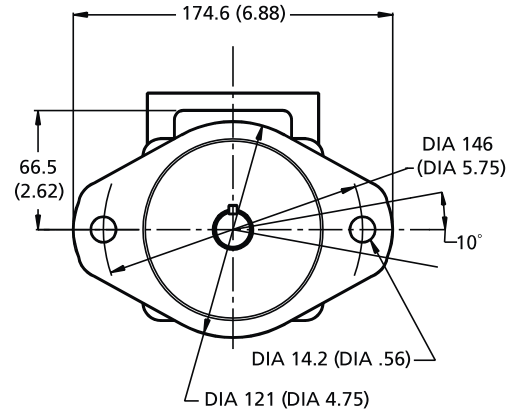
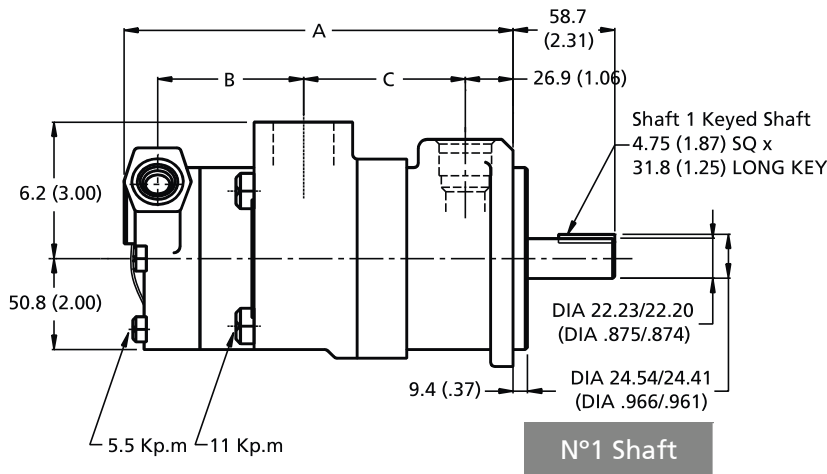
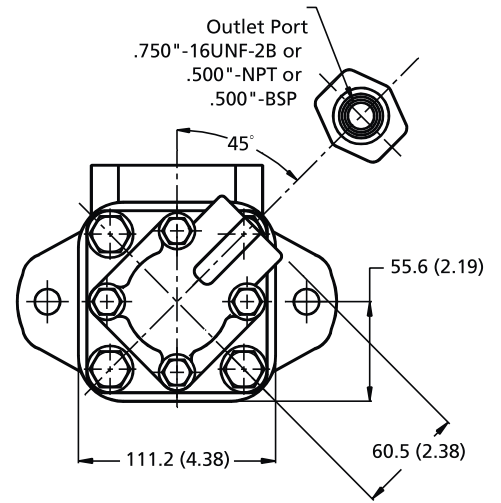
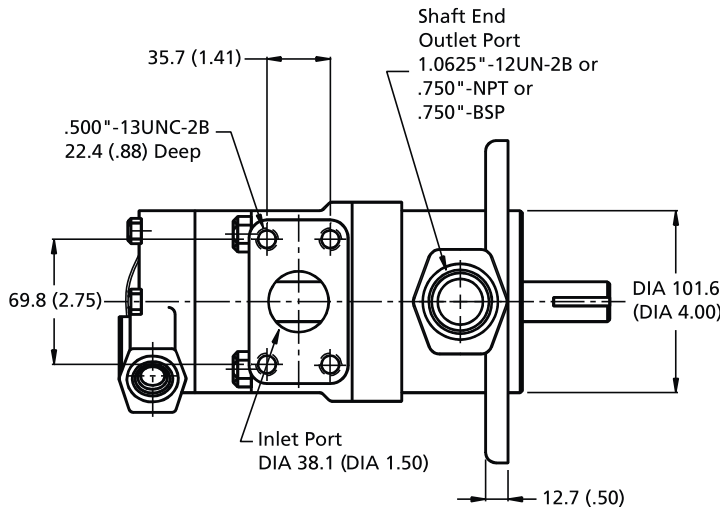

Delivery @ 1200 RPM & 7 Bar (100 psi)		DIMENSION		
SHAFT END	COVER END	A	B	C
5, 6, 7, 8, 9	1, 2, 3, 4, 5, 6, 7	213,1	75,9	86,4
		8.39	2.99	
		219,5	82,3	
		8.64	3.24	
10, 11	1, 2, 3, 4, 5, 6, 7	224,5	87,4	91,2
		8.84	3.44	
		229,6	87,4	
		9.04	3.44	
12, 13	1, 2, 3, 4, 5, 6, 7	221,7	75,9	94,7
		8.73	2.99	
		227,8	82,3	
		8.97	3.24	
		232,9	87,4	
		9.17	3.44	

VC-20

FLOW AND INPUT POWER DIAGRAMS



----- Max. pressure (180 bar) _____ Min. Pressure (7 bar)

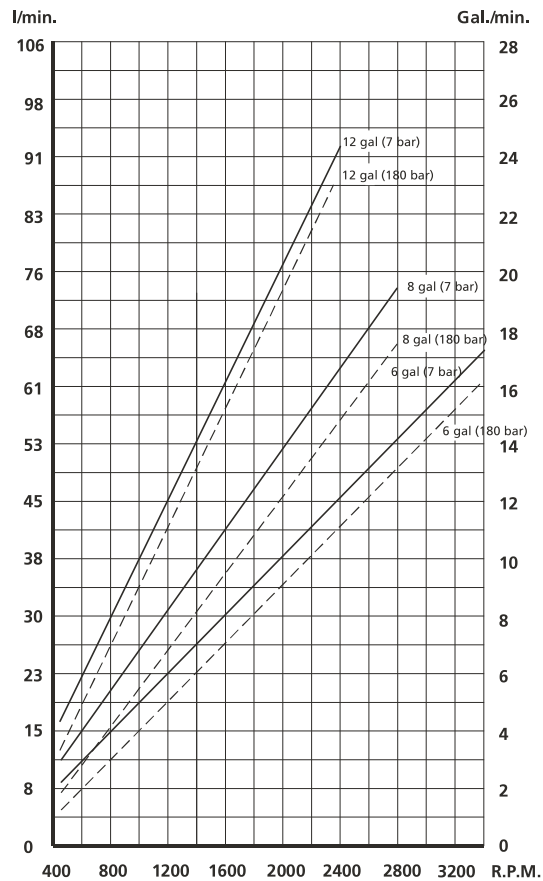
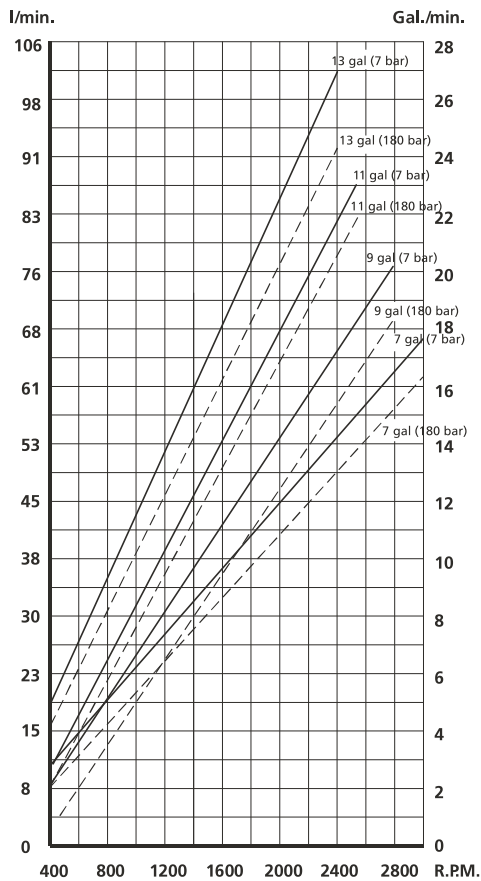
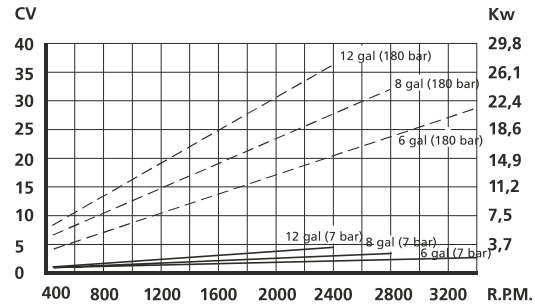
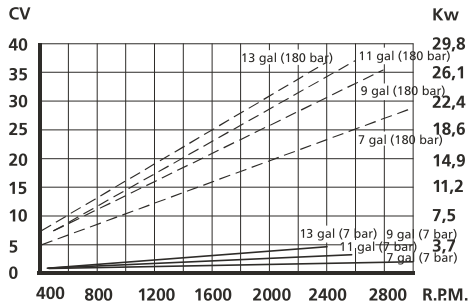

VC-10

FLOW AND INPUT POWER DIAGRAMS



Max. pressure (180 bar)

Pressure (7 bar)

