

ORDERING CODE

DATA SHEET

	F3	VS	25	21	D	1	A	00	
F3 - SPECIAL SEALS FOR FIRE-RESISTANT FLUIDS. Omit if not required								SPECIAL CHARACTERISTICS Omit if not required 02: BSP 03: UNF 04: NPT	
PUMP TYPE VC = 12 vane pump VC10, VC20 Mobile and industrial use VK = 10 vane pump VK20 Industrial use, unc threads.								PORTING COMBINATION A: Outlet in line with inlet. B: 90° clockwise from inlet. C: 180° from inlet. D: 90° counterclockwise from inlet. Viewed from shaft end of pump	
VS = 12 vane pump VS25, VS35, VS45 Industrial use (very quiet), UNC threads									
VQ = 10 vane pump Bronze plates VQ20, VQ25, VQ35, VQ45, VS25, VS35, VS45 Mobile use, UNC threads									
PUMP MODEL VC10, VC20; VK20, VQ20; VS25, VQ25; VS35, VQ35; VS45, VQ45								SHAFT TYPE See shaft options on pump dimension pages.	
FLOW VC, VS and VQ Gallons per minute @1200 rpm and 7 bar								ROTATION D = Clockwise rotation. Y = Counterclockwise Viewed from shaft end of pump	

PORTING COMBINATION

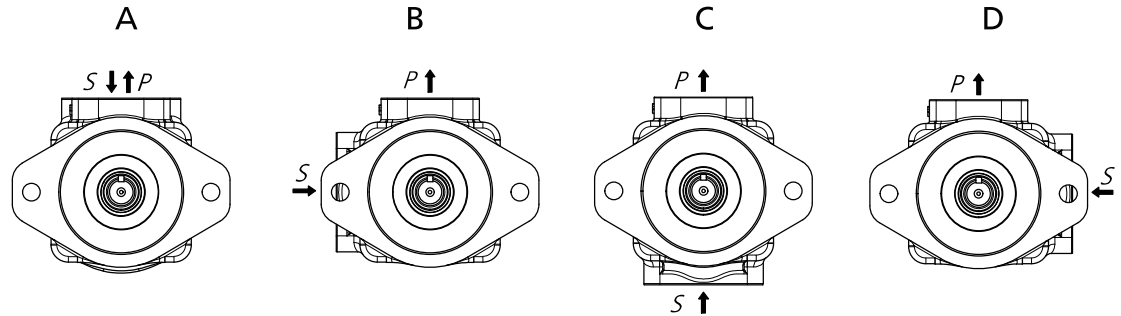

CHARACTERISTICS

TYPE	FLOW			SPEED(rpm)		PRESSURE (bar)		NOMINAL POWER	CONNECTION		WEIGHT		
	VICKERS	L @ 1000RPM	GAL. @ 1200RPM	REDUCTION (1)	MIN	MAX	CONT	INTERMIT	(2)	INLET	OUTLET	KG	
VC10		3	1	0,8	600	4800	155	180	0,7	(3)	(3)	4,5	
		6	2	0,9					4500				1,4
		9	3	1,2					4000				2,1
		13	4	1,6					3400				2,7
		16	5	1,7					3400				3,2
		19	6	1,8					3000				3,7
		22	7	1,9					2800				4,2
VC20		19	6	2,8	600	3400	155	180	3,9	(3)	(3)	7,3	
		22	7	4,2					3000				4,4
		26	8	4,5					2800				5,1
		29	9	4,8					2800				5,6
		36	11	4,8					2500				6,5
		39	12	5,4					2400				7,5
		42	13	6,0					2400				8,1
VQ20 VK20		8	2	0,9	600	2600	175	210	1,9	Ø 1 1/2"	Ø 3/4"	12	
		18	5	2,1					4				
		27	8	2,8					6,6				
		29	9	3,5					6,9				
		36	11	4,3					7,3				
		39	12	4,3					7,4				
		46	14	5,3					7,6				
VQ25 VS25		32	10	5,1	600	2500 1800 (VS)	175	210	8,6	Ø 1 1/2"	Ø 1"	15	
		40	12	5,7					10,4				
		45	14	5,7					11,6				
		55	17	5,8					13,8				
		60	19	5,8					14,6				
		67	21	6					16,8				
		80	25	6,2					1500				125
VQ35 VS35		66	21	8,6	600	2400 1800 (VS)	175	210	16,8	Ø 2"	Ø 1 1/4"	23	
		81	25	9					20,3				
		97	30	10					24,3				
		112	35	11,4					27,4				
		121	38	11,4					29,3				
		142	45	13,1					1500				125
VQ45 VS45		138	42	15	600	2200 1800 (VS)	155	175	32,3	Ø 3"	Ø 1 1/2"	35,5	
		148	45	15,7					36,3				
		162	50	14,3					37,9				
		180	57	17,9					43,2				
		193	60	18,6					46,1				
		214	67	22					51,2				
		240	75	26					57,4				

(1) Delivery flow reduction in Ltrs./min. at 100 Bar. 22 cST of oil viscosity at operating temperature. To calculate the approximate delivery flow at a given pressure and speed, use the following formula with flow reduction and theoretical flow values shown in the chart. Flow reduction values are independent of shaft speed.

$$\text{Approx. output flow (Ltrs./min.)} = \text{Theoretical flow} \times \frac{\text{R.P.M}}{1000} - \text{Reduction} \times \frac{\text{Pressure (Bar)}}{1000}$$

(2) Nominal Power in H.P. at 100 Bar and 1000 RPM (to convert into Kw multiply by 0.735). To obtain the real input power at different pressure and revolutions, use the formula as follows:

$$\text{Real input power} = \text{Input power} \times \frac{\text{R.P.M}}{1000} \times \frac{\text{Pressure (Bar)}}{1000}$$

(3) See options on dimension pages.

VS-35 / VQ-35 DIMENSIONS

DATA SHEET

	FLOW						SPEED(rpm)		PRESSURE (bar)		CONNECTION		WEIGHT
	Lts/min.at 1000 rpm	66	81	97	112	121	142*	Min.	Máx.*	Contin.*	Intermit.*	Inlet	Outlet
Gal/min.at 1200 rpm	21	25	30	35	38	45*	600	2400	175	210	Ø2"	Ø1" 1/4	23

* See page 27

DIMENSIONS IN MILLIMETERS. 1" = 25,4 mm

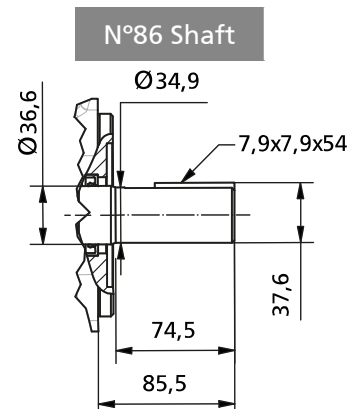
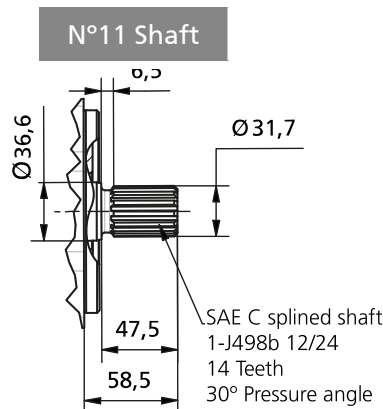
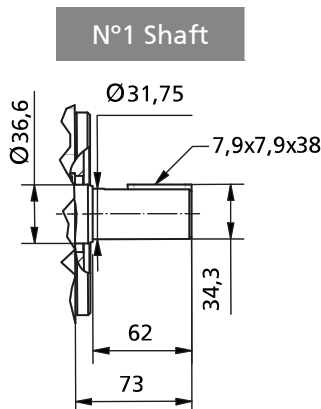
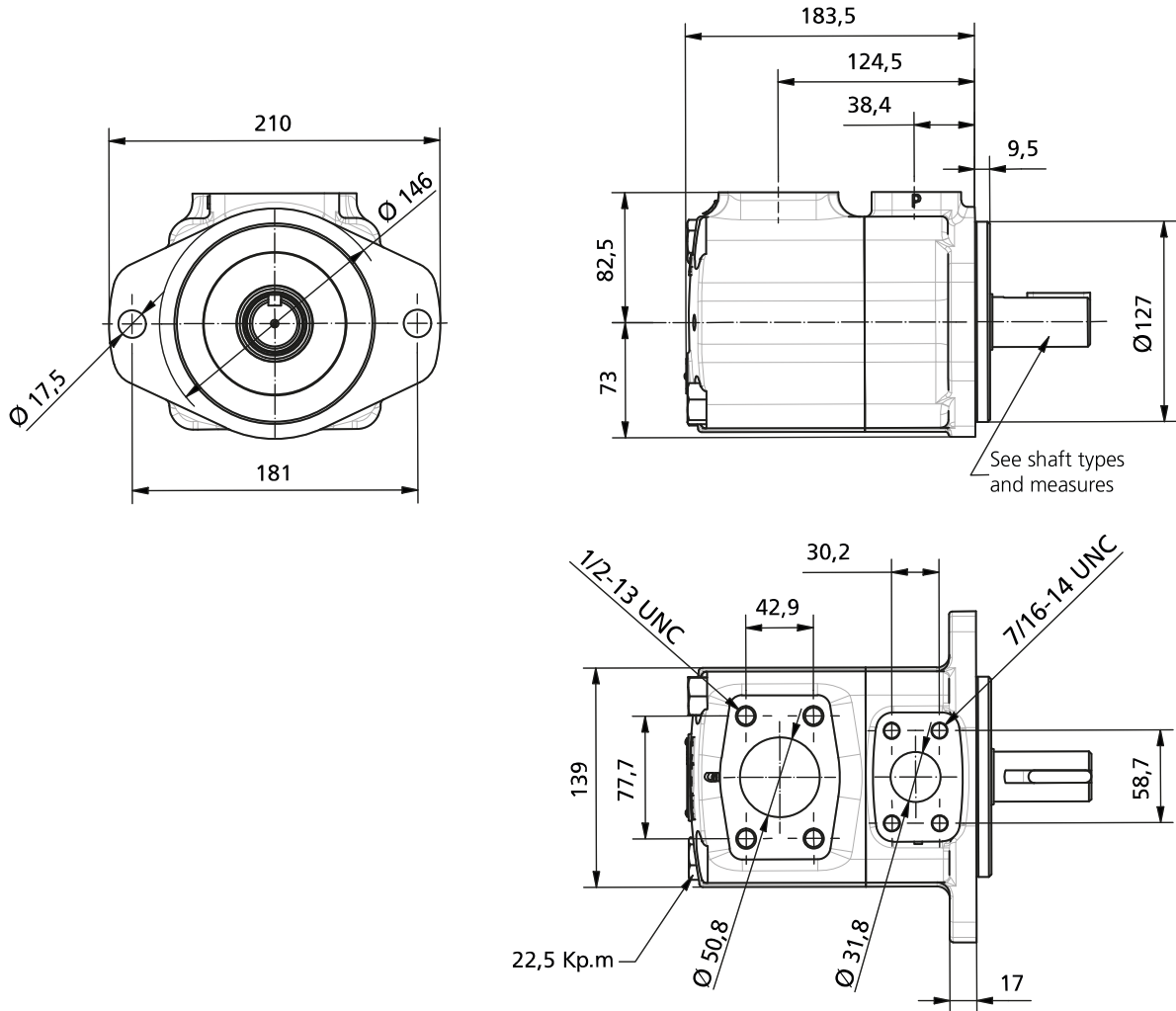

ADDITIONAL SHAFT CODES: SEE ON PAGES 114-118

VS-35 / VQ-35

FLOW AND INPUT POWER DIAGRAMS

